



Multisport Serie 452

BEDIENUNGSANLEITUNG
SC24 AUTONOM
BEDIENPULT "24 SEKUNDEN"



Zeichnungen und Bilder unverbindlich

● ALLGEMEINES

Lieferumfang	
Bedienpult <ul style="list-style-type: none"> ✓ Dient zur Eingabe der Angriffszeiten (Basketball). 	
Akkuladegerät 12V 500mA <ul style="list-style-type: none"> ✓ Dient zum Aufladen des Akkus des Bedienpultes. ✓ Nur das von STRAMATEL gelieferte Ladegerät benutzen. 	
Flexibles Kabel 10 Meter (für Modelle mit der Option zusätzliches Kabelset) <ul style="list-style-type: none"> ✓ Für die Verbindung des Bedienpultes (5-poliger Einbaustecker) mit der Anzeigetafel, über der Anschlußdose. ✓ Nur die von STRAMATEL gelieferten Kabeln benutzen. 	





Aufladung des Bedienpultes	
<p>Das Bedienpult besitzt Batterien für eine Dauer von ungefähr 20 Stunden bei Vollladung. Außerhalb der Spiele muss das Bedienpult ständig anhand dem Akkuladegerät zur Aufladung bleiben (nur das von STRAMATEL gelieferte Ladegerät benutzen).</p> <ul style="list-style-type: none"> ✓ Das Bedienpult ausschalten. ✓ Das Akkuladegerät an das Bedienpult anschließen und danach an das 100-240V Stromnetz (eine Steckdose soll sich in der Nähe des Gerätes befinden und leicht zugänglich sein). <p><u>Das Bedienpult muß ständig auf Ladung stehen, auch wenn es nicht gebraucht wird (System mit langsamer Ladung, ohne Verbrauch der Batterien). Nur das von STRAMATEL gelieferte Ladegerät benutzen.</u></p>	

Spielregeländerungen (USB Stick)	
<p>Das Programm des Bedienpultes kann bei Spielregeländerungen anhand eines USB Sticks umgerüstet werden.</p> <p>Eine Anleitung wird gegebenenfalls beigelegt.</p>	







Tastenfunktionen des Bedienpultes

















Die Tasten sind von 1 bis 4 nummeriert

	ON / OFF des Bedienpultes
	Starten oder Stoppen des Timers Programmierung der Dauer (langes Drücken > 5 Sekunden, bei Inbetriebnahme des Pultes)
	Stoppen und Löschen des Timers Zugang zur Programmierung der Sprachauswahl oder zur Programmierung des Steuerungsmodus des Bedienpultes (langes Drücken > 1 Sekunde, bei Inbetriebnahme des Pultes)
	Aufladen des Timers auf 14 Sekunden Korrektur des Timer-Wertes (langes Drücken > 1 Sekunde)
	Aufladen des Timers auf 24 Sekunden Korrektur des Timer-Wertes (langes Drücken > 1 Sekunde)











● DIVERSE KONFIGURATIONEN

Änderung und Speicherung der Angriffszeiten	
Die Angriffszeiten (24 und 14 Sekunden) können geändert werden. Die Daten bleiben beim Ausschalten des Bedienpultes gespeichert.	
Drücken Sie die Taste ON/OFF bis die Willkommensmeldung erscheint.	
Halten Sie die Taste 1 gedrückt, sobald die Willkommensmeldung erscheint: das Bedienpult ist im Programmiermodus "24 Sekunden".	
Die Zeit mit Taste 2 dekrementieren oder mit Taste 3 inkrementieren. Mit Taste 1 bestätigen: das Bedienpult ist im Programmiermodus "14 Sekunden".	
Die Zeit mit Taste 2 dekrementieren oder mit Taste 3 inkrementieren. Mit Taste 1 bestätigen: die Angriffszeiten sind im Bedienpult gespeichert.	
Schalten Sie das Bedienpult durch Drücken der Taste ON/OFF aus.	

Sprachauswahl des Bedienpultes	
Das Bedienpult ist in verschiedenen Sprachen programmierbar.	
Drücken Sie die Taste ON/OFF bis die Willkommensmeldung erscheint.	
Der Ladungsstand des Akkus ist auf dem LCD-Bildschirm des Bedienpultes angezeigt. Falls die Ladung zu schwach ist, schließen Sie das gelieferte Ladegerät an das Bedienpult an.	
Drücken Sie während 1 Sekunde auf die Taste 2 .	
Wählen Sie den Modus "Language" mit Taste 1 .	
Wählen Sie die gewünschte Sprache mit den Tasten 2 und 3 (Liste) und mit Taste 1 bestätigen.	
Schalten Sie das Bedienpult durch Drücken der Taste ON/OFF aus.	

Steuerungsmodus des Bedienpultes	
Das Bedienpult ist mit 6 verschiedenen Funkkanälen ausgerüstet und kann auch mit einem zusätzlichen Kabelset gesteuert werden.	
Drücken Sie die Taste ON/OFF bis die Willkommensmeldung erscheint.	
Der Ladungsstand des Akkus ist auf dem LCD-Bildschirm des Bedienpultes angezeigt. Falls die Ladung zu schwach ist, schließen Sie das gelieferte Ladegerät an das Bedienpult an.	
Drücken Sie während 1 Sekunde auf die Taste 2 .	
Wählen Sie den Modus "Funk" mit Taste 4 .	
Wählen Sie einen der verschiedenen Funkkanäle oder die Kabelsteuerung (die Funksteuerung wird deaktiviert) mit den Tasten 2 und 3 (Liste) und mit Taste 1 bestätigen.	
Schalten Sie das Bedienpult durch Drücken der Taste ON/OFF aus.	

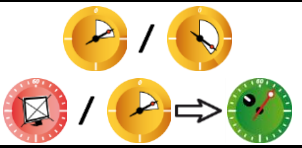
● ANWENDUNG WÄHREND DEM SPIEL

Inbetriebnahme	
Drücken Sie die Taste ON/OFF bis die Willkommensmeldung erscheint.	
Der Ladungsstand des Akkus ist auf dem LCD-Bildschirm des Bedienpultes angezeigt. Falls die Ladung zu schwach ist, schließen Sie das gelieferte Ladegerät an das Bedienpult an.	
Zeitmessung	
Starten oder stoppen Sie den Timer mit Taste 1.	
Stoppen Sie den Timer und löschen Sie die Zeit auf der Anzeige mit Taste 2.	
Die Angriffszeit 14 Sekunden mit Taste 3 aufladen.	
Wenn die 14 Sekunden unabsichtlich aufgeladen wurden: zurück zur vorherigen Zeit durch erneutes Drücken der Taste 3 (Funktion abrufbar solange die 14 Sekunden angezeigt sind).	
Die Angriffszeit 24 Sekunden mit Taste 4 aufladen.	
Wenn die 24 Sekunden unabsichtlich aufgeladen wurden: zurück zur vorherigen Zeit durch erneutes Drücken der Taste 4 (Funktion abrufbar solange die 24 Sekunden angezeigt sind).	
Korrektur des Timers: <ul style="list-style-type: none"> ✓ In den Korrekturmodus gehen: drücken Sie während 1 Sekunde auf die Taste 3 oder 4. ✓ Die Zeit mit Taste 2 dekrementieren oder mit Taste 3 inkrementieren. Mit Taste 1 bestätigen. 	
Signalhorn	
Das Hupensignal ertönt automatisch: <ul style="list-style-type: none"> ✓ nach Ablauf der Angriffszeit. 	
Lichtsignal (rote Leutzeichen)	
Auf jeder Anzeige leuchtet automatisch ein rotes Leuchtzeichen auf: <ul style="list-style-type: none"> ✓ nach Ablauf der Angriffszeit. 	
Nach Spielende	
Schalten Sie das Bedienpult durch Drücken der Taste ON/OFF aus.	

Multisport 452

OPERATING INSTRUCTIONS





SC24 AUTONOM

"24 SECONDS" CONTROL CONSOLE



Non-binding pictures





● GENERALITIES

Scope of delivery	
<p>Control console</p> <ul style="list-style-type: none"> ✓ The console enables to control the ball possession time in basketball. 	
<p>12V 500mA power supply</p> <ul style="list-style-type: none"> ✓ The power supply enables to recharge the batteries of the control console. ✓ Use only the power supply supplied by STRAMATEL. 	
<p>10-meter flexible cable (Model supplied with the cable kit option)</p> <ul style="list-style-type: none"> ✓ The 10-meter flexible cable enables to connect the control console (5 pin-sockets) to the display units via the wall junction box. ✓ Use only the cable supplied by STRAMATEL. 	
Control console recharge	
<p>The control console is equipped with batteries allowing a battery life of about 20 hours when totally charged. Whilst not in use, the control console must be recharged with the power supply supplied. (Use only the power supply supplied by STRAMATEL).</p> <ul style="list-style-type: none"> ✓ Switch off the control console. ✓ Plug the power supply into the back of the control console, then plug it into an appropriate mains outlet (the socket should be as close as possible to the control console and must be easily accessible). <p><u>The control console should remain in recharge permanently whilst not in use (Slow charging system does not deteriorate the batteries). Use only the power supply supplied by STRAMATEL.</u></p>	
In case of new sports rules (USB key)	
<p>In case of new sports rules, the programme of the control console can be updated using a simple USB key.</p> <p>In this case, a specific instruction for programme update will be provided with the USB key.</p>	
	











Functions of the control console





















Keys are numbered from 1 to 4

	ON/OFF
	Start / stop of the timer Programming of the time lengths (long key pressing > 5 seconds as soon as the console is starting)
	Stop / erasing of the timer Access to the configuration of the language or to the configuration of the control console transmission mode (long key pressing > 1 second when starting the console)
	Re-loading of the timer with 14 seconds Correction mode (timer) (long key pressing > 1 second)
	Re-loading of the timer with 24 seconds Correction mode (timer) (long key pressing > 1 second)









● VARIOUS CONFIGURATIONS

Programming and backup of the time lengths	
The time lengths (24 and 14 seconds) can be modified. These data are saved in memory in case the control console is switched off.	
Press the ON/OFF key until the console displays the welcome screen.	
As soon as the control console displays the welcome screen: keep key 1 pressed: the control console enters in "24 seconds" programming mode.	
Shorten the time with key 2 or increase it with key 3. Enter with key 1: the control console enters in "14 seconds" programming mode.	 /  → 
Shorten the time with key 2 or increase it with key 3. Enter with key 1: the time lengths programmed are saved in memory in the control console.	 /  → 
Switch off the control console by keeping the ON/OFF key pressed.	

Language of the control console	
The control console is programmable in different languages.	
Press the ON/OFF key until the console displays the welcome screen.	
The remaining battery charge level is indicated next. If the battery charge is insufficient, power can be supplied by plugging in the power supply supplied.	
Keep key 2 pressed for 1 second.	
Select "Language" with key 1.	
Select the language needed with keys 2 and 3 (drop-down list) and enter the choice with key 1.	 /  → 
Switch off the control console by keeping the ON/OFF key pressed.	

Control console transmission mode	
The control console is equipped with 6 different pre-set transmission frequencies (channels) and can also be used in cable transmission mode.	
Press the ON/OFF key until the console displays the welcome screen.	
The remaining battery charge level is indicated next. If the battery charge is insufficient, power can be supplied by plugging in the power supply supplied.	
Keep key 2 pressed for 1 second.	
Select "Radio" with key 4.	
Select the radio channel needed or the cable transmission mode (the radio transmission mode is off) with keys 2 and 3 (drop-down list) and enter the choice with key 1.	 /  → 
Switch off the control console by keeping the ON/OFF key pressed.	

● DURING THE MATCH

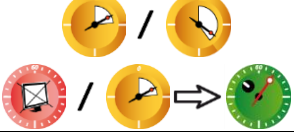
Set-up	
Press the ON/OFF key until the console displays the welcome screen.	
The remaining battery charge level is indicated next. If the battery charge is insufficient, power can be supplied by plugging in the power supply supplied.	
Timing	
Start or stop the timer with key 1.	
Stop the timer and erase the time on the display units with key 2.	
Load the timer with 14 seconds with key 3.	
If the timer has been loaded to 14 seconds by mistake: come back to the previous time by pressing key 3 again (this function is available as long as the control console displays 14 seconds).	
Load the timer to 24 seconds with key 4.	
If the timer has been loaded to 24 seconds by mistake: come back to the previous time by pressing key 4 again (this function is available as long as the control console displays 24 seconds).	
Correction of the time length: <ul style="list-style-type: none"> ✓ Enter in correction mode by keeping key 3 or key 4 pressed during 1 second. ✓ Shorten the time with key 2 or increase it with key 3. Enter with key 1. 	
Horn	
The horn sounds automatically: <ul style="list-style-type: none"> ✓ at the end of the ball possession time. 	
Warning light (red light)	
The red light of each display unit lights up automatically: <ul style="list-style-type: none"> ✓ at the end of the ball possession time. 	
End of the match	
Switch off the control console by keeping the ON/OFF key pressed.	